

# Introducing Integrated Fluid Control

Fluid Distribution Solution Optimizing System Cost, Efficiency and Complexity

Scalable integrated coolant control module simplifying vehicle thermal management systems. Integrating the functions of a pump and valve into a flexible family of products.

- Eliminates independent valves
- Reduces system pressure drop
- Optimizes tube and adaptor routing
- Reduces joints and connection points
- Reduces wiring, connections and I/O channels
- Integrates to existing vehicle architectures
- Reduces space requirements by 50%
- Enhances vehicle range



Electric Vehicle



Enhanced use of Payload



Reduced Emissions



Improved Lifecycle

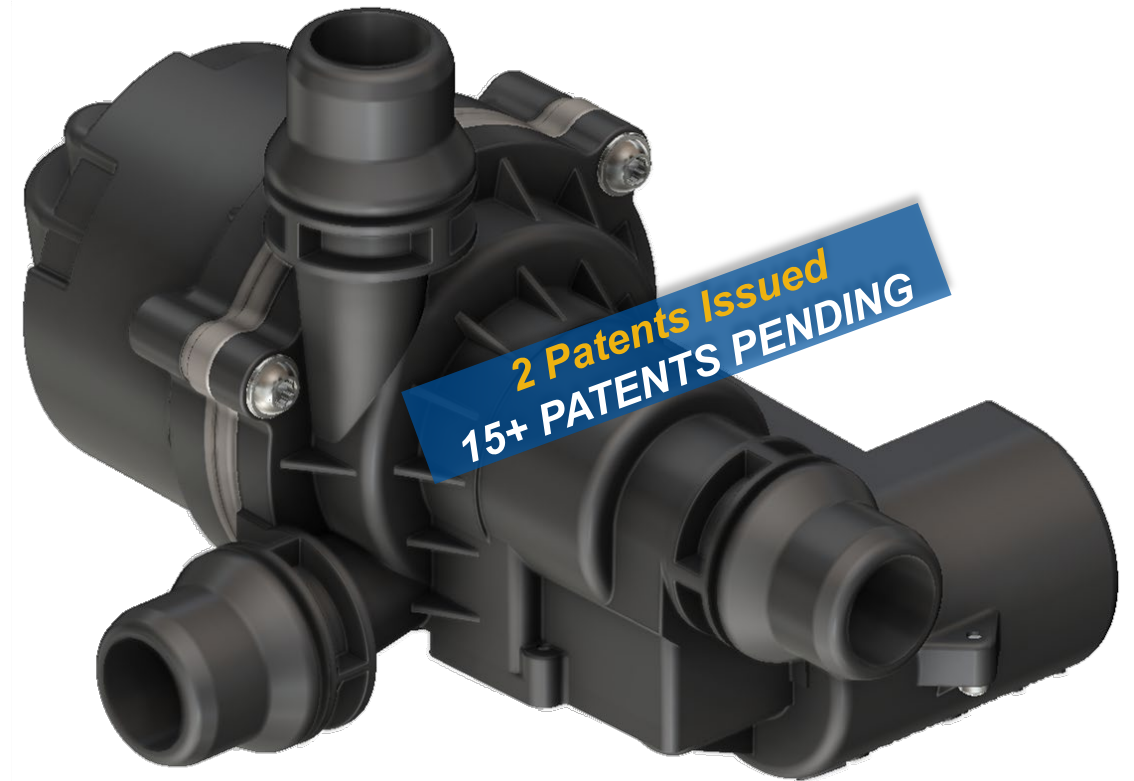

Outlet Ports: 1 to 4

Port Types: Hose, Tube Barb, Male VDA Male